

A man with a mustache, wearing a white lab coat, is focused on adjusting a large, dark piece of machinery. The scene is lit with a cool, blueish light. Overlaid on the image are several orange technical diagrams, including a circular schematic with arrows and labels, and a complex circuit board layout with various components like resistors, capacitors, and transistors. The word "RELIATOR" is prominently displayed in the center in a bold, white, sans-serif font.

RELIATOR

The background of the slide is a technical wireframe illustration of industrial machinery, including what appears to be a robotic arm on the left and a large cylindrical vessel or reactor on the right. The lines are white and set against a background that transitions from a dark teal at the top to a bright orange at the bottom.

INNOVATIV TEKNIK FÖR FRAMTIDEN

VÅRT ERBJUDANDE





Maskinteknik



Process- och
Energiteknik

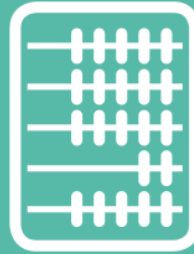

Beräkningsteknik



Projektledning
och beställarstöd



Riskanalys
och CE-
märkning

Framtid

Innovativ!

Farligt

Miljövänligt!

Explosivt

Vad är vätgas?

Fossilt

Utvecklat!

Dyrt

Bränsle

Energi

RELTOR
ENGINEERING



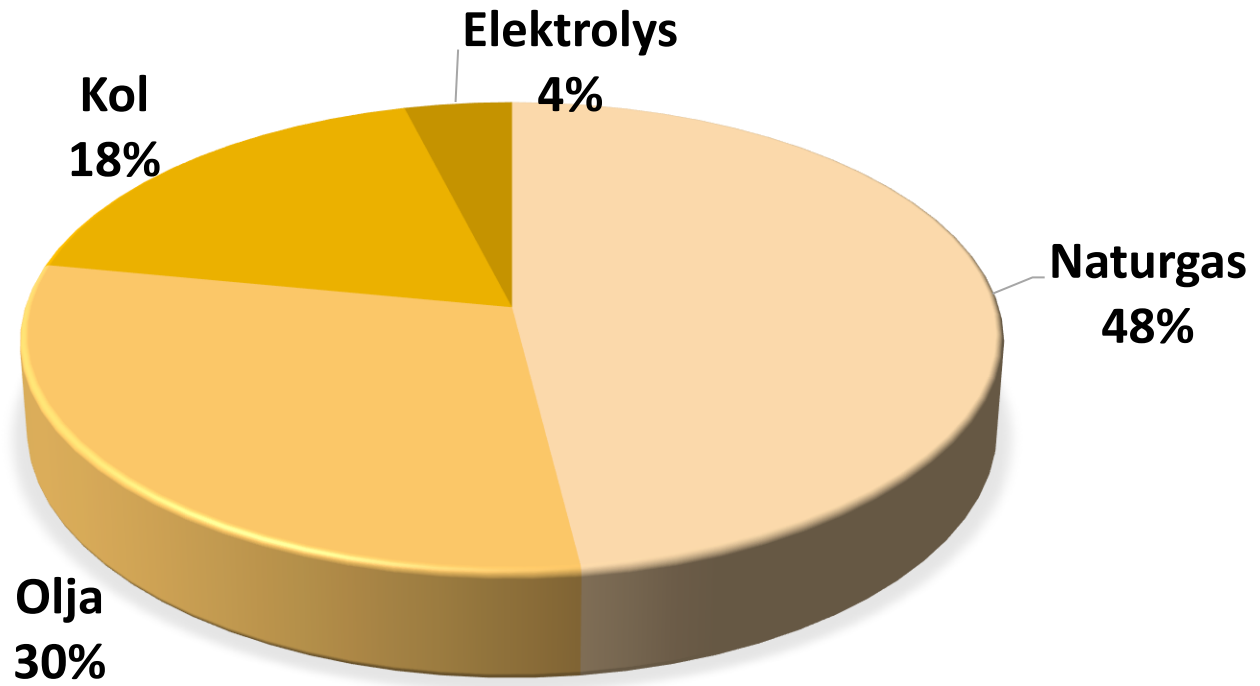
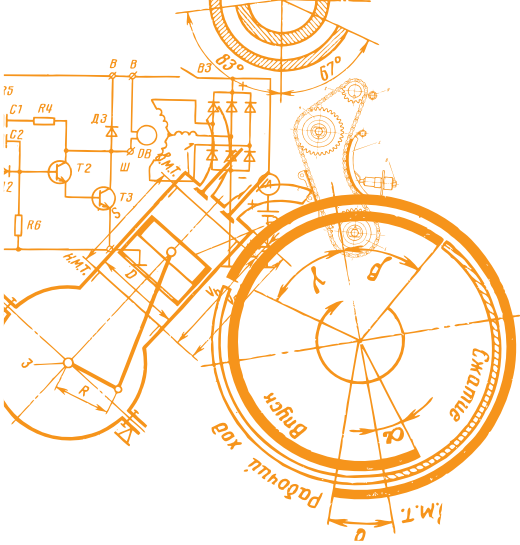

Reformering av naturgas

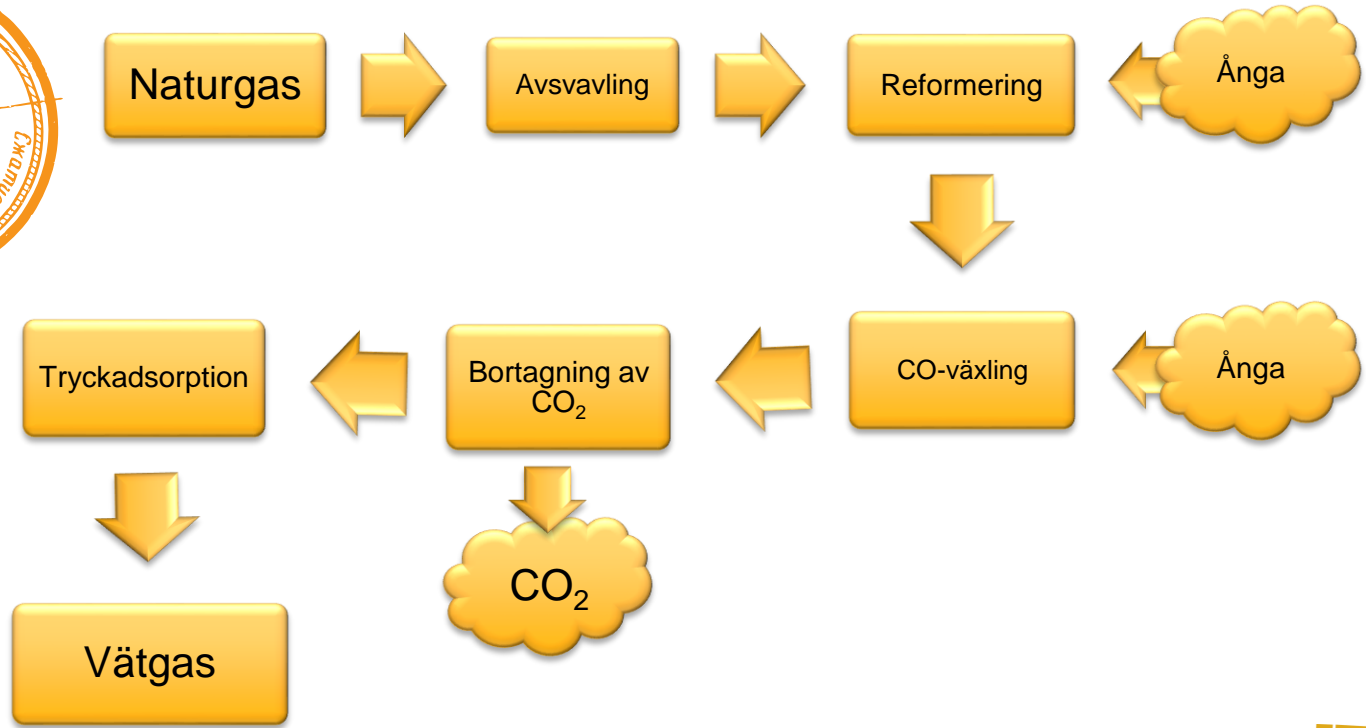
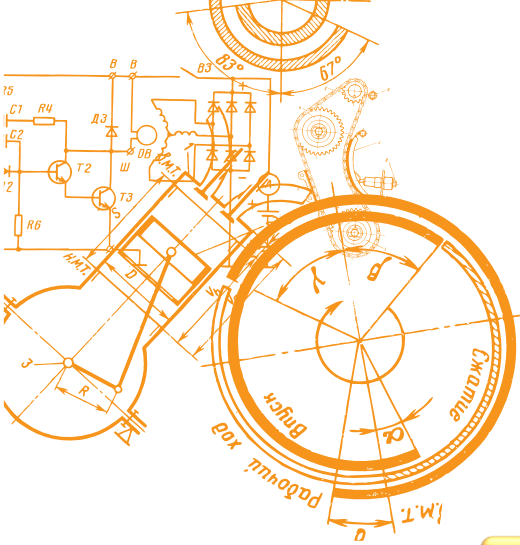

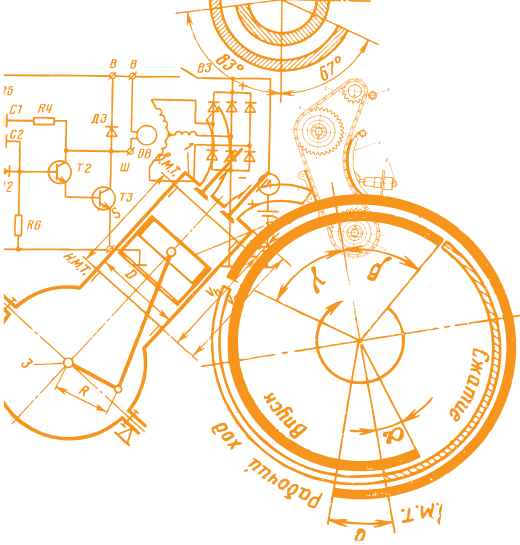

Elektrolyt

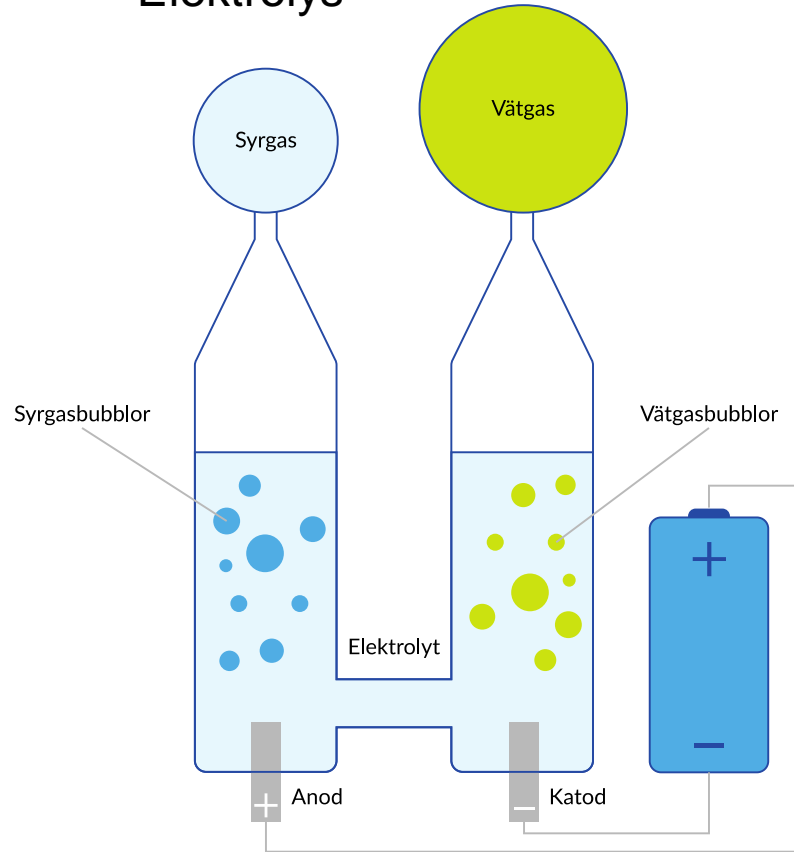

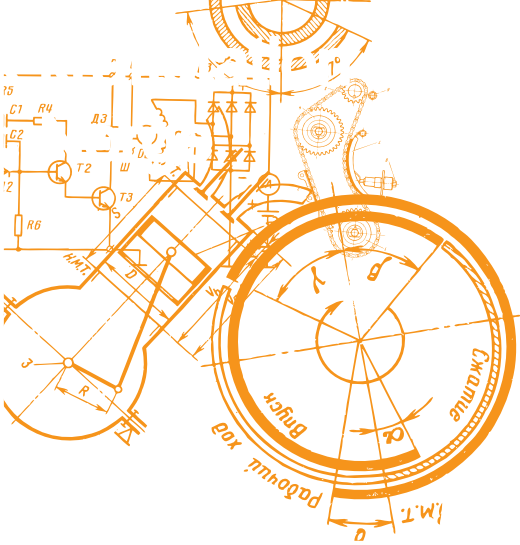

Vätgaslagring

Komprimerad form
200, 550, 700 eller \approx 900 bar



Vätgas i historien



Hindenburgsyndromet

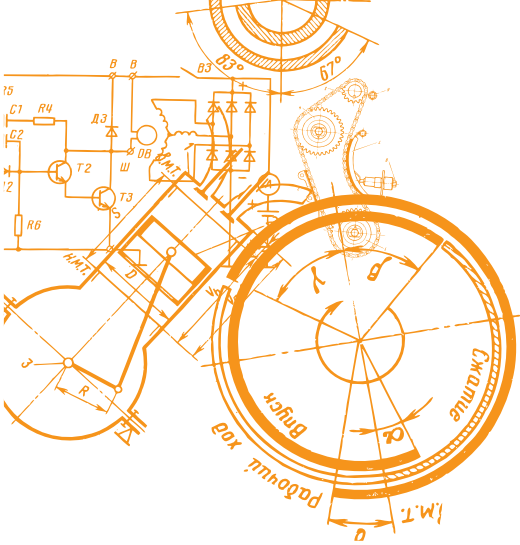

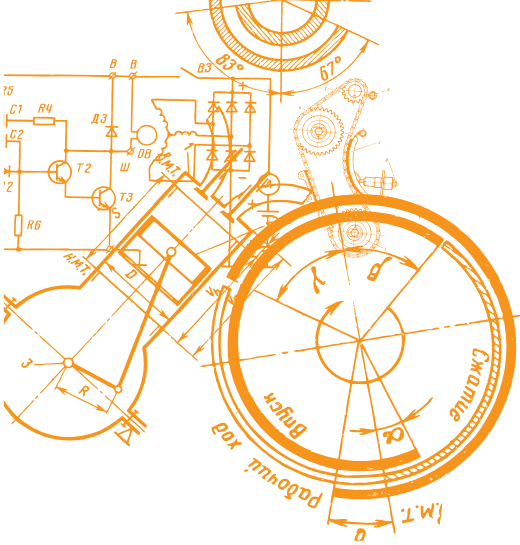

Vemork kraftstation Rjukan, Norge

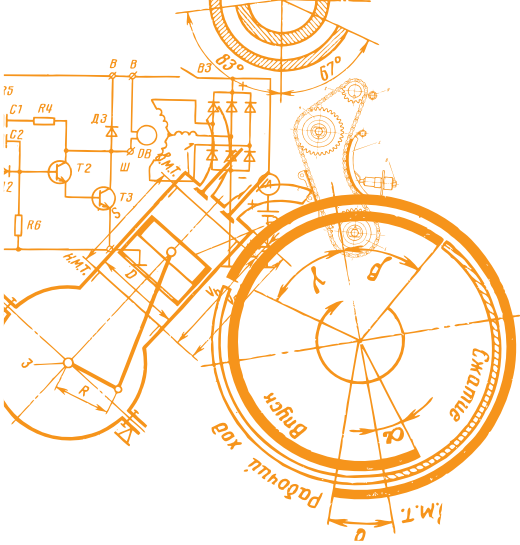

Rjukan, Norge

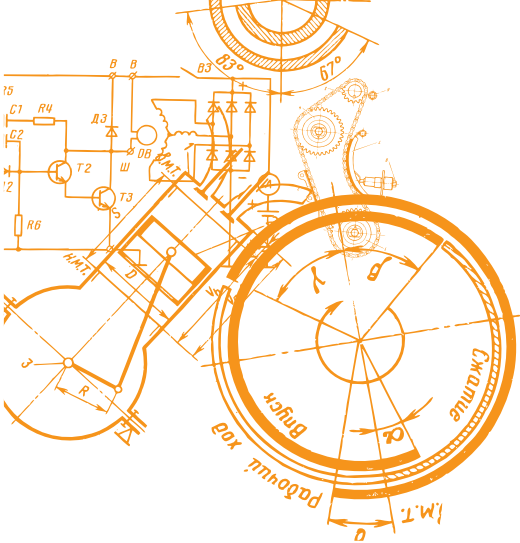

Glomfjord, Norge

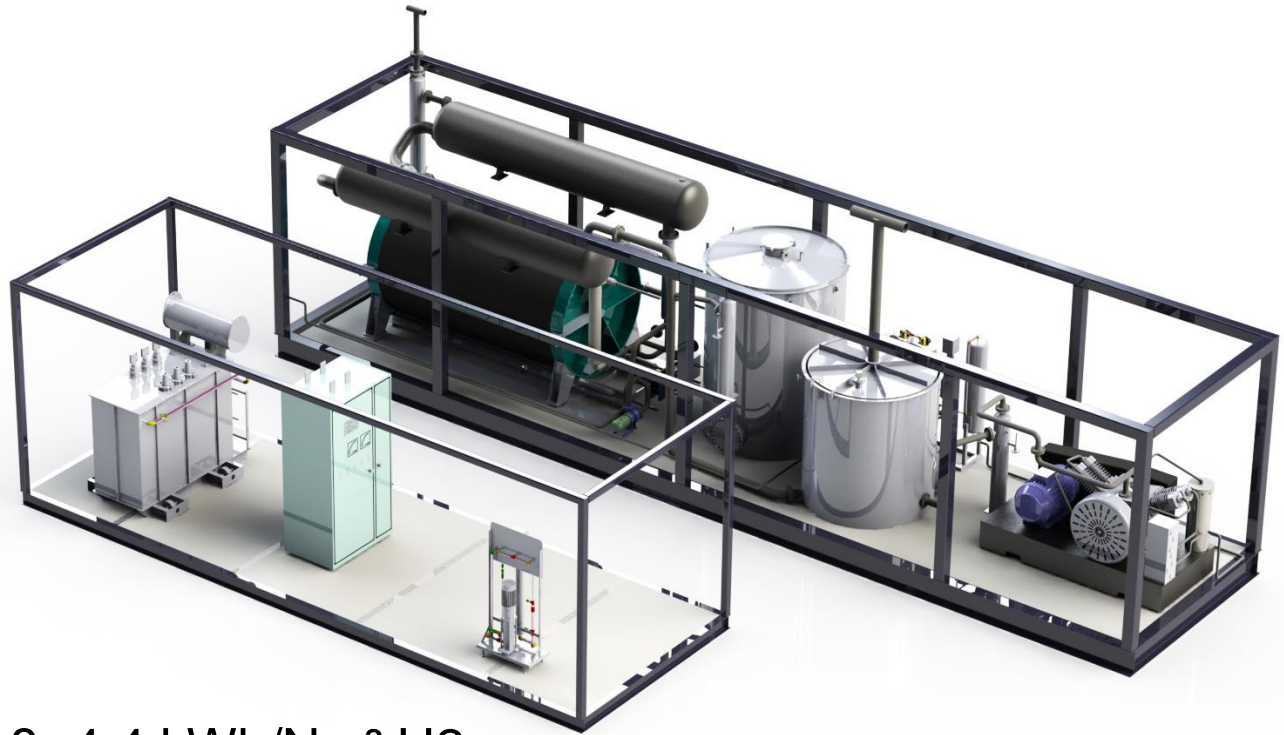
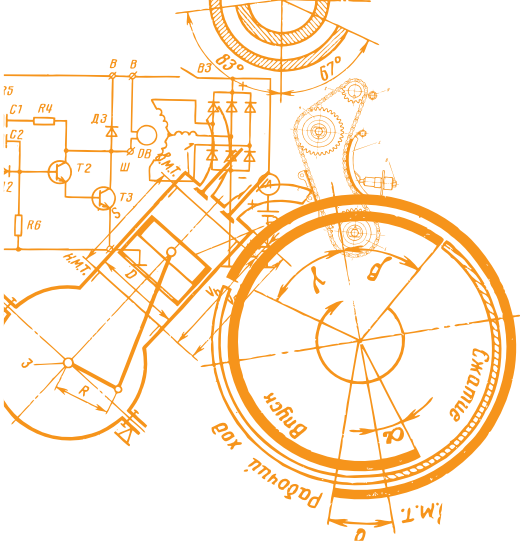

Energiförbrukning $\approx 3,8- 4,4 \text{ kWh/Nm}^3 \text{ H}_2$

Verkningsgrad $\approx 70/80 \%$

Ca 1 liter vatten per $\text{Nm}^3 \text{ H}_2$

Ekonomi

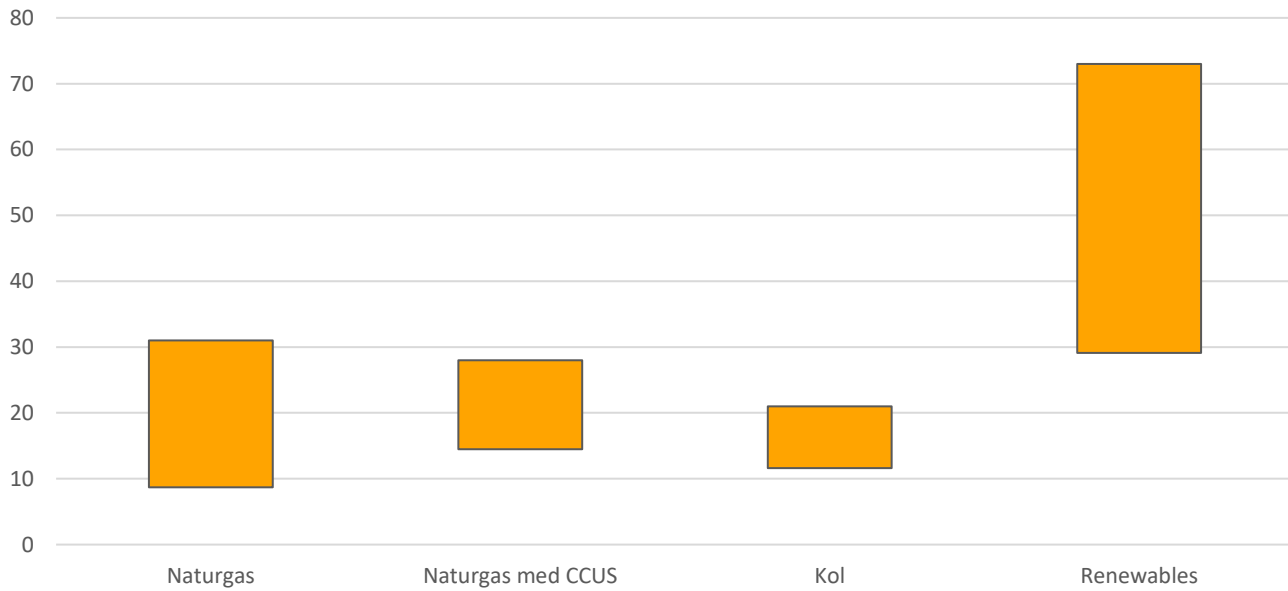
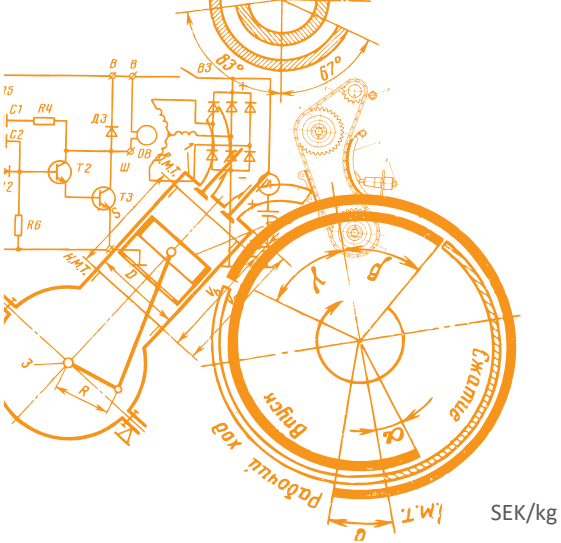

Användningsområden & Potential med vätgas

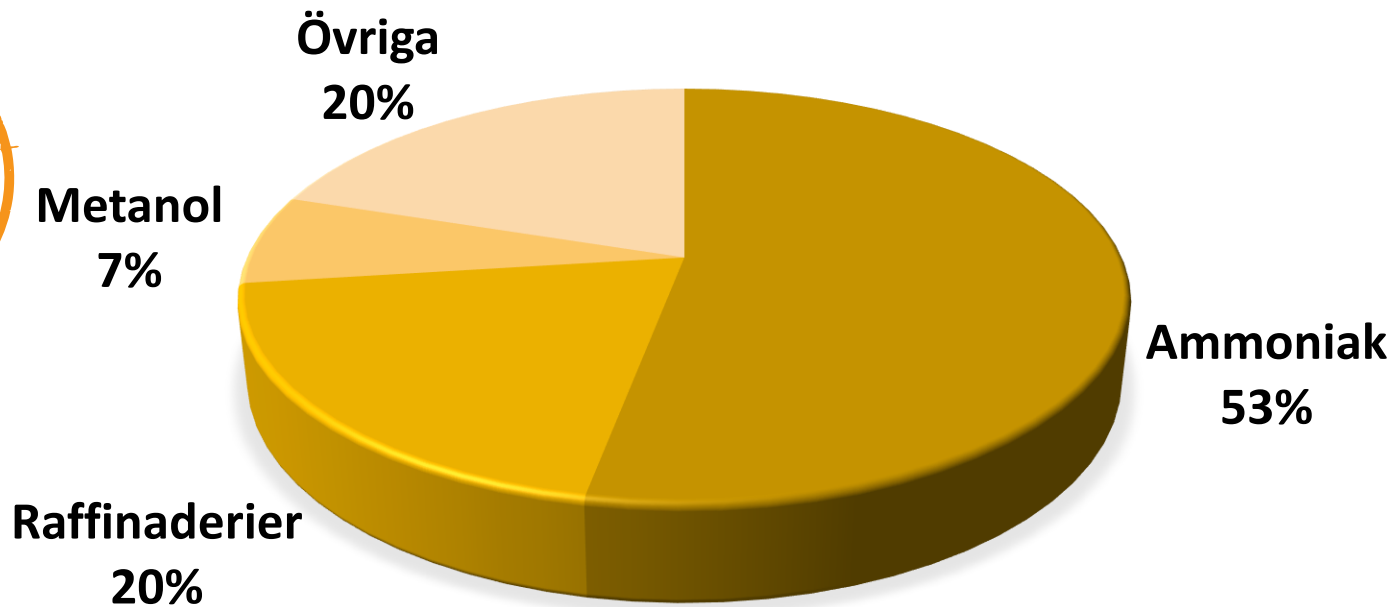
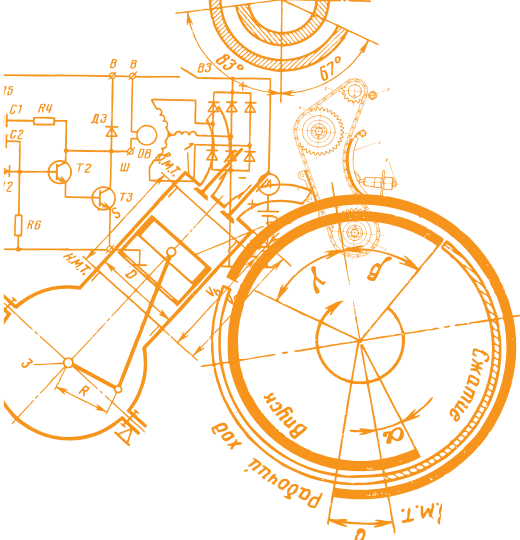

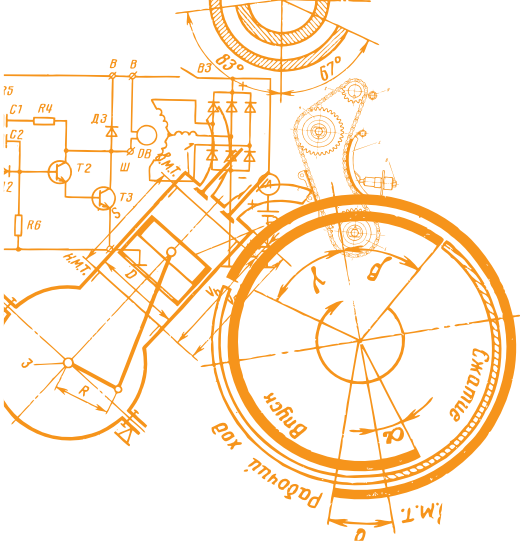

Lab applikationer

Väteperoxid, polymerer och lösningsmedel

Mättade fetter

Läkemedelsindustri

Svetsning

Metallurgiska applikationer

Polysilikon för wafer tillverkning (Solceller)

Raket bränsle (i flytande form!)

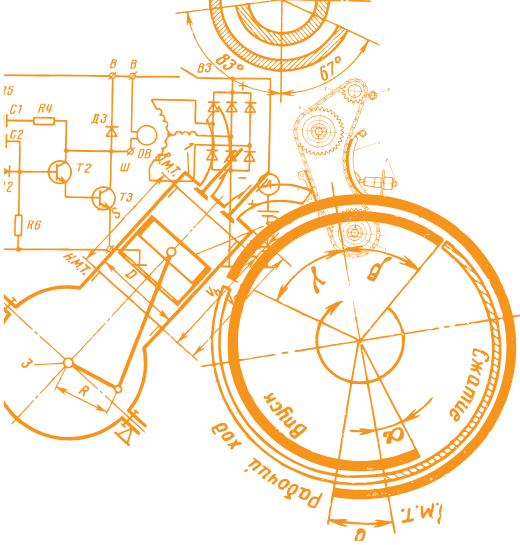

Vätgas som energibärare

Knyter behovet att storskaligt kunna lagra el
med behovet av att få fram mer förnybara
drivmedel

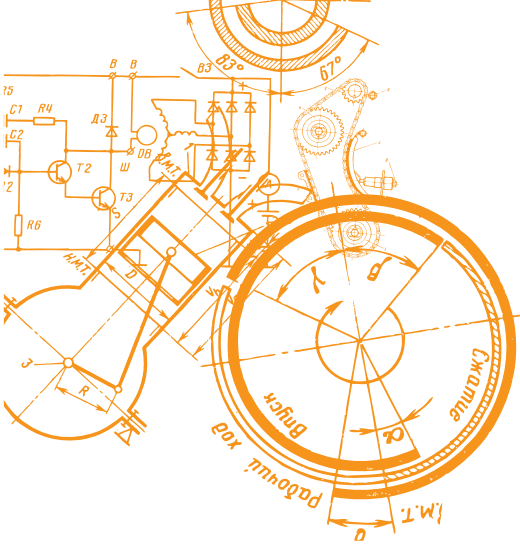

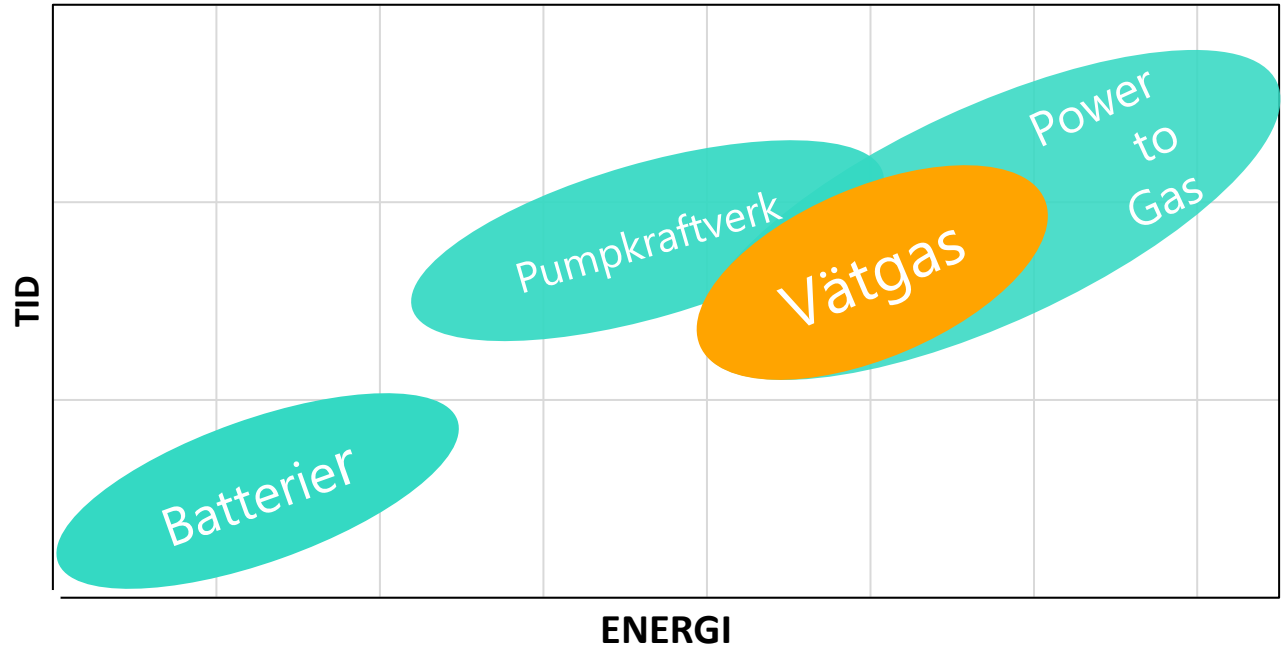
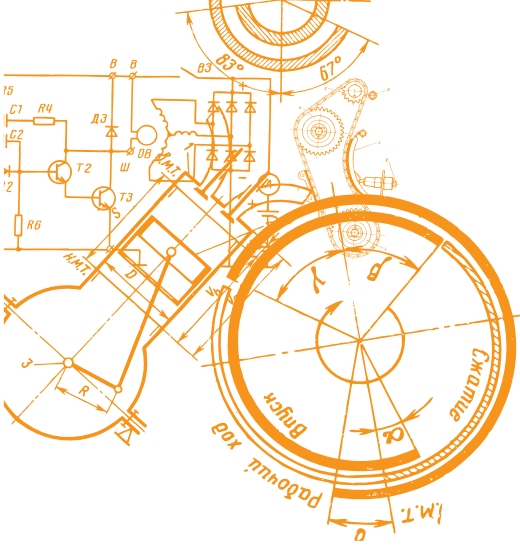

För- och nackdelar

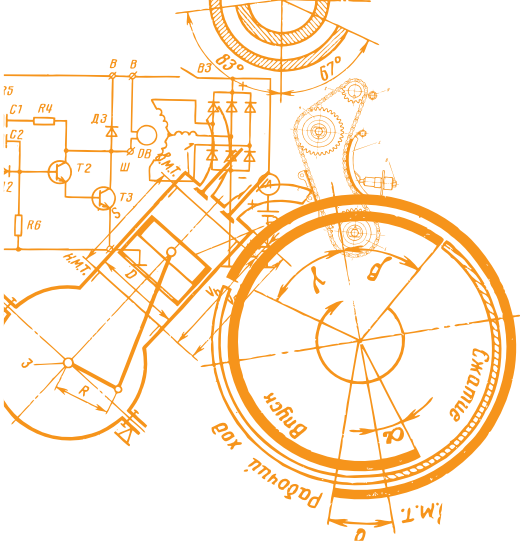

Fördelar

Ingen kolbaserade utsläpp

Känd och beprövad teknik

Hög energidensitet

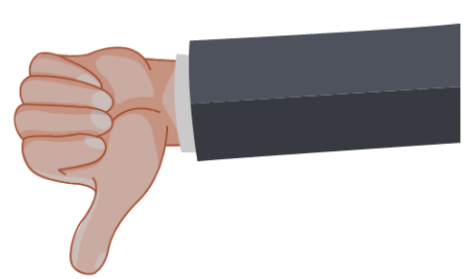
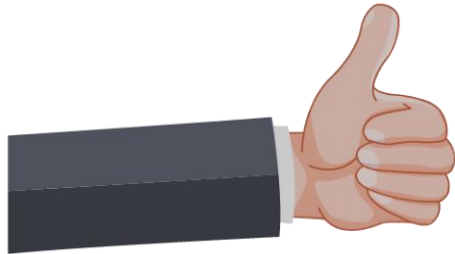

Nackdelar

Lagring kräver hög tryck

Brandfarlig och explosiv

Kostnad

Säkerhet

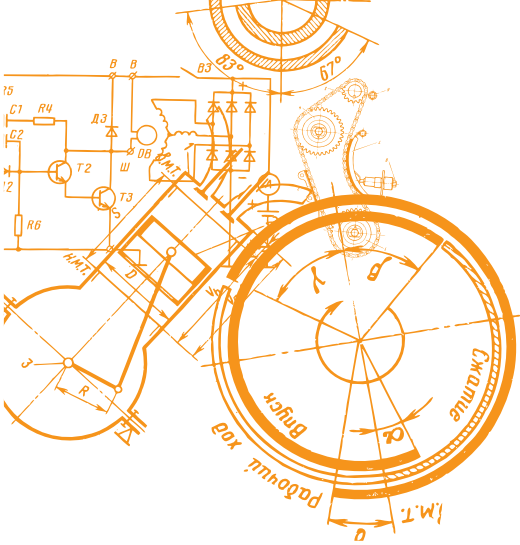

ATEX direktiv - 2014/34/EU

HAZOP studies - SS-EN 61882

Ex-komponenter för användning i explosiv atmosfär - SS-EN 60079-0

Identification and assessment of hazardous situations - SS-EN 1127

Maskinsäkerhet – SS EN ISO 12100



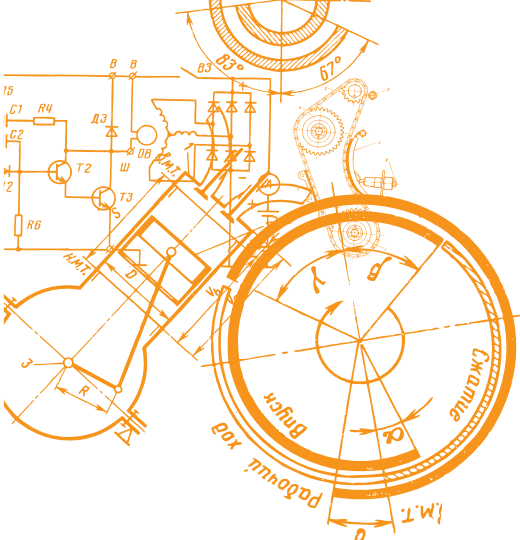

Om det är så enkelt...

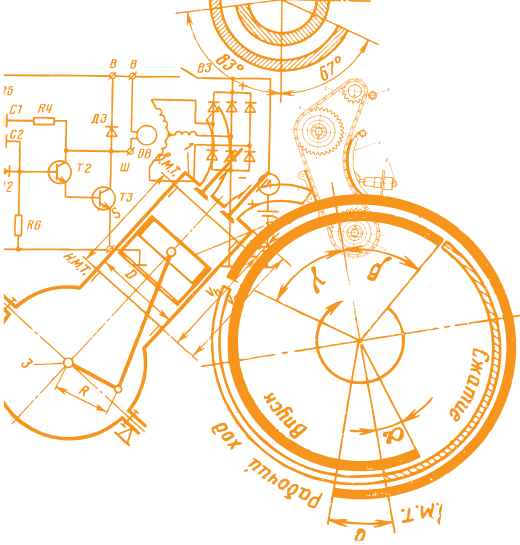

Hinder för vätgasinfrastruktur

Politik

Okunskap

Kostnader

Samhällsvinster med vätgas

Miljövinster

Nya affärs- och produktionsmöjligheter

Försörjningstrygghet

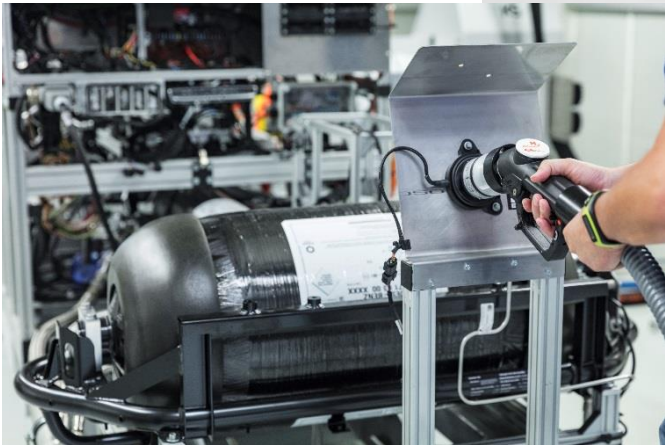
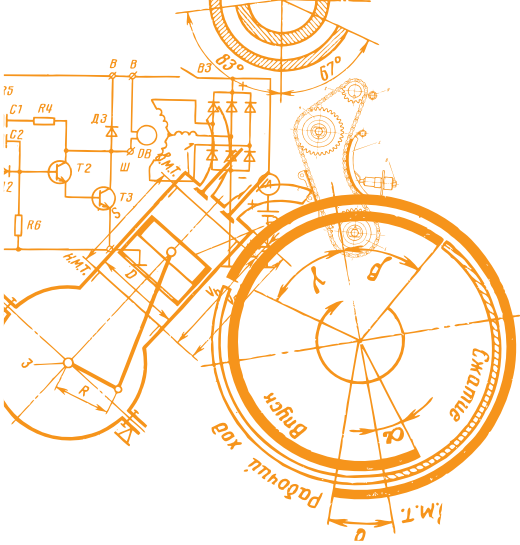

Tack för att ni lyssnat!

www.relitor.se

VILL DU VETA MER OM OSS?

